



# Multi Angle 400/1000 Magvise Operation and Instruction Manual

Magswitch Technology Inc.  
8774 Yates Dr #140  
Westminster, Co 80031  
www.Magswitch.com.au

These Magswitch Multi Angle Tools Are Designed To Hold Small And Medium Sized Pieces Of Steel In Place Until A Tack Weld Can Be Performed. Using Patented Technology, These Devices Have Tremendous Holding Power On All Sides Of The Side Plates, As Well As A Great Amount Of Shear Force Holding Strength To Reduce Sideways Movement. The unit can be positioned in order to use as an effective Magnetic Vise (Magvise). On/Off Control And Easy Cleaning Of Debris Make These The Perfect Choice!

**Read All Instructions! Failure To Follow All Instructions Listed Below May Result In An Unsafe Or Dangerous Condition.**

## General Information

- All magnets need to be *kept at a safe distance* from all magnetic storage devices, electronics and credit cards etc...
- Ensure that the Magswitch Multi Angle is *stored in the "off" position* when not in contact with Ferromagnetic metals. . The Multi Angle can be left ON or OFF indefinitely without harm. When ON and near Ferromagnetic metals there will be a sudden and powerful attraction.
- *Never use a Magswitch Multi Angle to lift any materials overhead or where their release would cause injury or property damage.*
- *DO NOT attempt to disassemble or alter* the Magswitch Multi Angle; there are no user serviceable parts inside the device.
- All Magswitch products are *designed for normal work/job site conditions*, do not use underwater or in a hazardous environment
- *DO NOT use the Magswitch Multi Angle if it is damaged or is not working properly.* Severe injury can occur if this device is not used properly and safely.
- *DO NOT expose the Magswitch magnets to temperatures above 176deg Fahrenheit (80 Celsius).* High temperatures will permanently degrade the magnet's effectiveness and may result in an unsafe condition.
- *Never use a Magswitch Multi Angle for OVERHEAD LIFTING* or to transport material.
- *Not recommended for painted or finish coated surfaces* as these will reduce the magnetic bond and the finish may be damaged.
- *This product contains PTFE lubricant.* For MSDS information contact Magswitch.
- *Always keep the bottom of the magnet and side plates clean and free of debris and rust.* If needed wipe with WD40 or light oil

## To use the Multi Angle (Mounts to flat or round Ferromagnetic steel)

- Always *test the connection* before attempting to use the Magswitch Multi Angle to ensure that it is capable of holding the material securely.
- *Numerous factors can negatively affect the strength* of the magnetic bond. Dirt, debris, oils and grease, painted surfaces and any gap between the magnet and the metal surface will decrease the bond. *Ensure that the connection point is clean* and free of these factors.
- *Thicker metals will be held more strongly than thinner metals..*E.g.: 1/4" (6mm) steel will be held more strongly than thin gauge metals.
- *Flat steel will be held more strongly than round bar stock or tube steel.*
- *Avoid sudden jerking or Shock force* as this will cause the magnet to lose its hold.
- *Never use the Multi Angle as a welding ground or as part of an electric circuit.*
- For safe operation, the *bottom surface of the Pole Plates must always be Flat and Smooth.* If necessary, it is possible to sand the Magnet face smooth using 400 grit sandpaper and a flat surface. *Always file any burrs* that would interfere with full contact.

## Multi Angle Operation

- *The handle on this Magswitch Multi Angle must be turned clockwise 180 degrees until it stops* in order to be turned "ON". It is not possible to hold the Magnet in place unless fully turned "ON". Turn ON only when in contact with ferromagnetic steel.
- *To release the magnetic hold, Press down on the handle and turn the handle in the counter clockwise direction until it stops. Remove all items attached to or hanging from the Multi Angle before turning off!* The Magnet will *turn off and release immediately* upon turning the handle, Use Caution to ensure that it is safe to release the magnet and that nothing will fall or become dangerous.
- This Magswitch Multi Angle is capable of *exceptional Break-Away force* holding power; Magswitch Magnets are exceptionally strong in *Shear Force* as well. *Prying force is the least powerful* of the holding capabilities and great care must be used when attempting to use this device with Pry force. *See illustrations below.*

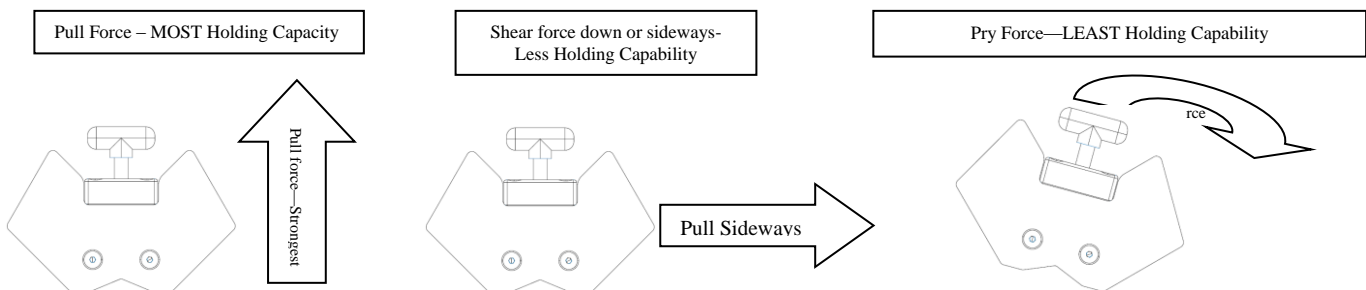

## Magswitch Limited Warranty

Magswitch products are covered by a One Year Limited Warranty on Material and Workmanship. Warranty is Non-Transferable.

Magswitch reserves the right to inspect all product claims under warranty. Any alteration of the device voids this warranty.

User assumes all risk for the proper use of this device and for ensuring product suitability for intended application.

This warranty shall not cover any incidental or consequential damages due to the improper use or failure of this device.

All Magswitch products are intended for the use identified on the package - not intended for resale or integration into products for resale. Contact Magswitch for inquiries on integration of technology. Australian Patent: 753496, Chinese Patent: 254155, New Zealand Patent: 518865, Singapore Patents: 88931; 103413, South Africa Patents: 2002/3752; 2004/1785, US Patents: 6,707,360; 7,012,495. Additional Patents and Patent Applications Pending.

Part Number 110599

Revision Date, February 23, 2012

# Magswitch Multi Angle 400 Diagram And Details

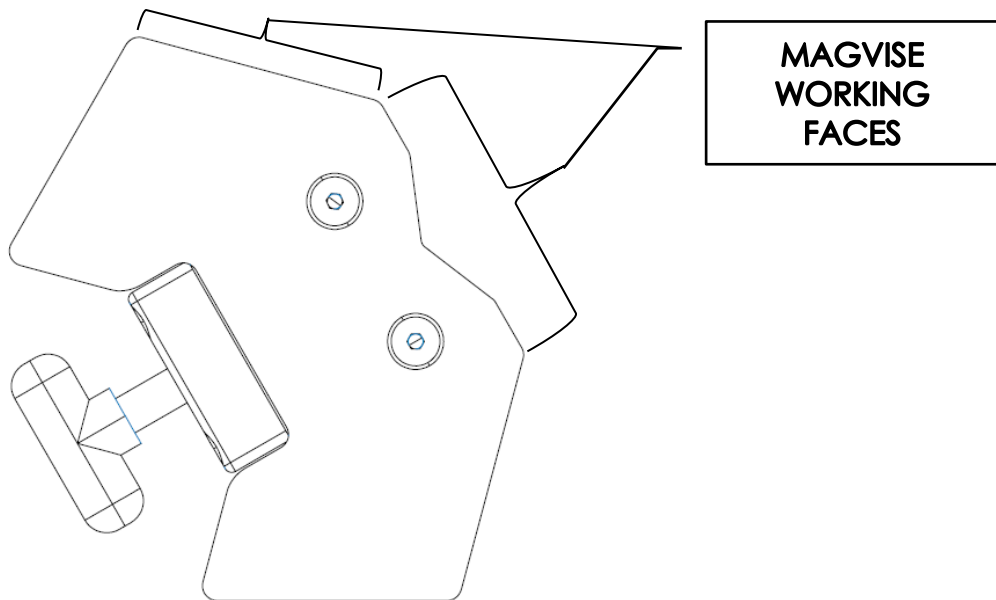
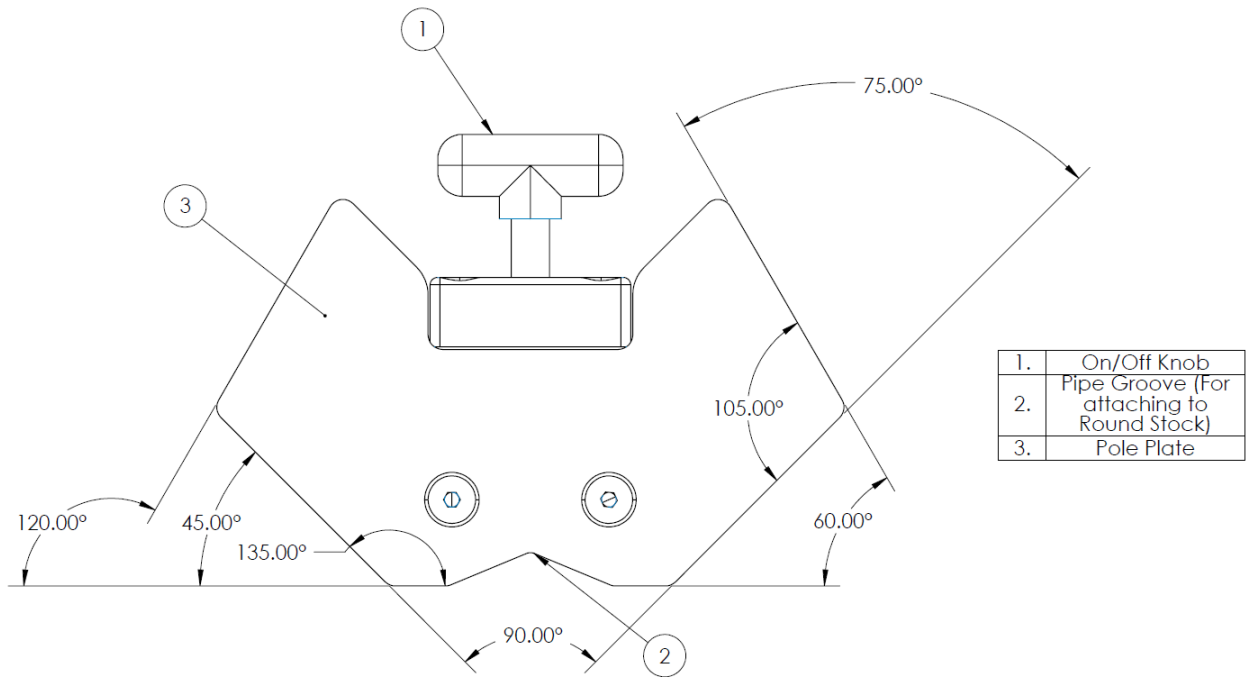

# Magswitch Multi Angle 1000 Diagram And Details

